



US007059288B2

(12) **United States Patent**  
**Merrick et al.**

(10) **Patent No.:** **US 7,059,288 B2**

(45) **Date of Patent:** **Jun. 13, 2006**

(54) **RETAINER FOR CONNECTOR**

(75) Inventors: **Andrew D. Merrick**, Lombard, IL (US); **Franco Franchi**, Wood Dale, IL (US)

(73) Assignee: **International Engine Intellectual Property Company, LLC**, Warrenville, IL (US)

(\*) Notice: Subject to any disclaimer, the term of this patent is extended or adjusted under 35 U.S.C. 154(b) by 0 days.

(21) Appl. No.: **10/836,291**

(22) Filed: **Apr. 30, 2004**

(65) **Prior Publication Data**

US 2004/0237922 A1 Dec. 2, 2004

**Related U.S. Application Data**

(60) Provisional application No. 60/466,867, filed on Apr. 30, 2003.

(51) **Int. Cl.**  
**F02P 19/00** (2006.01)  
**H05B 3/06** (2006.01)  
**F23Q 7/22** (2006.01)

(52) **U.S. Cl.** ..... **123/145 A**; 24/458; 219/267; 292/17

(58) **Field of Classification Search** ..... 123/145 R, 123/145 A, 470; 219/267, 270; 24/296, 24/457, 458; 439/125; 292/17  
See application file for complete search history.

(56) **References Cited**

**U.S. PATENT DOCUMENTS**

2,667,004 A \* 1/1954 Sanson ..... 24/106  
2,779,377 A \* 1/1957 Flora ..... 411/15  
2,983,535 A \* 5/1961 Henning ..... 292/17  
3,115,225 A \* 12/1963 Fraylick et al. .... 24/297  
6,539,905 B1 \* 4/2003 Estacio et al. .... 123/145 A

**FOREIGN PATENT DOCUMENTS**

JP 11107898 \* 4/1999

\* cited by examiner

*Primary Examiner*—T. M. Argenbright

(74) *Attorney, Agent, or Firm*—Susan L. Lukasik; Dennis Kelly Sullivan; Jeffrey P. Calfa

(57) **ABSTRACT**

An apparatus that may be utilized as a glow plug connector (1401) includes a retainer (1601) disposed between retainer flanges (2415), advantageously in a groove (2413). The retainer (1601) is capable of compressing to fit, for example, within a passage of a rocker carrier (820) of an internal combustion engine, and capable of subsequently expanding to prevent the connector (1401) from being dislodged from the passage.

**19 Claims, 14 Drawing Sheets**

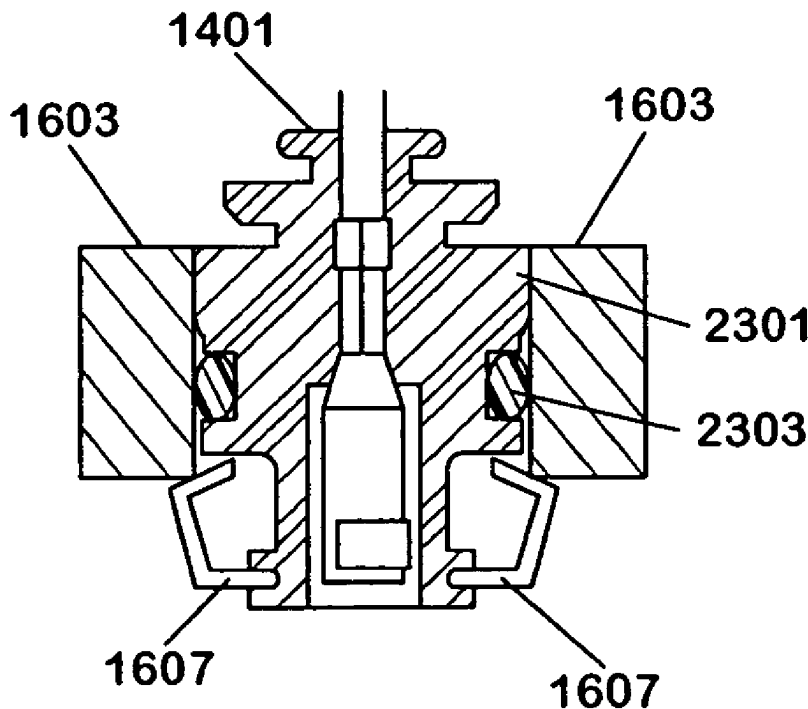

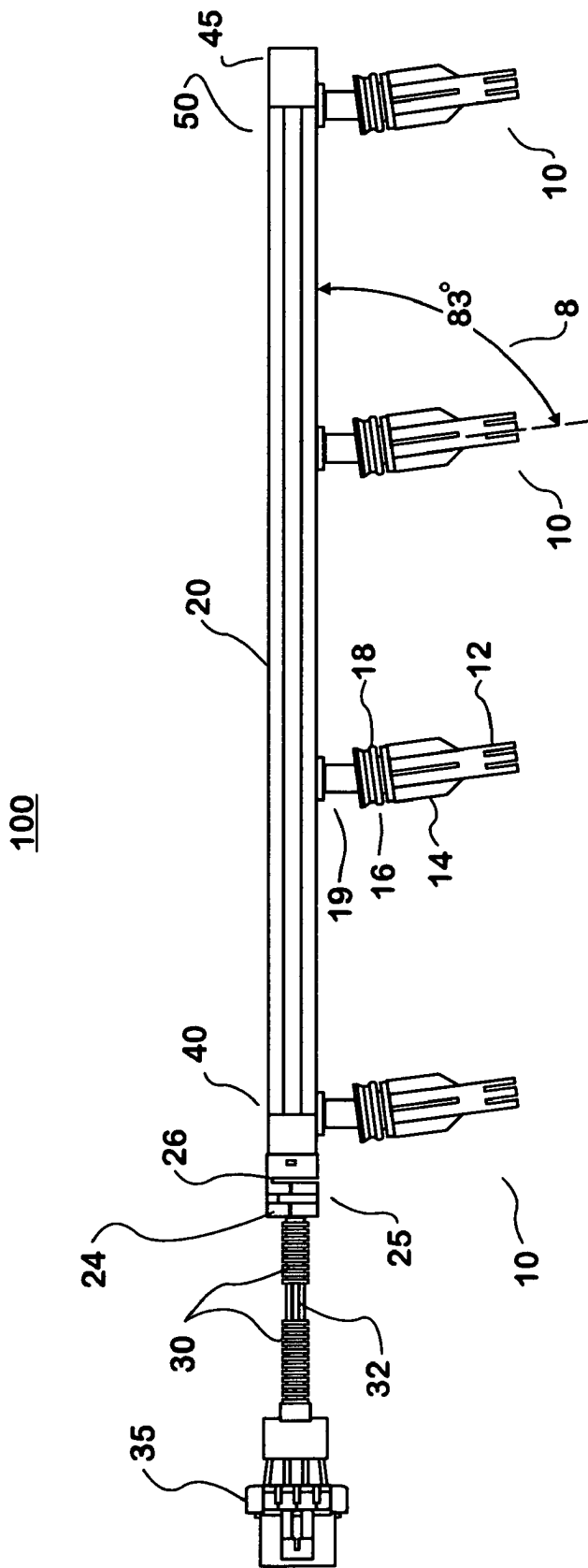
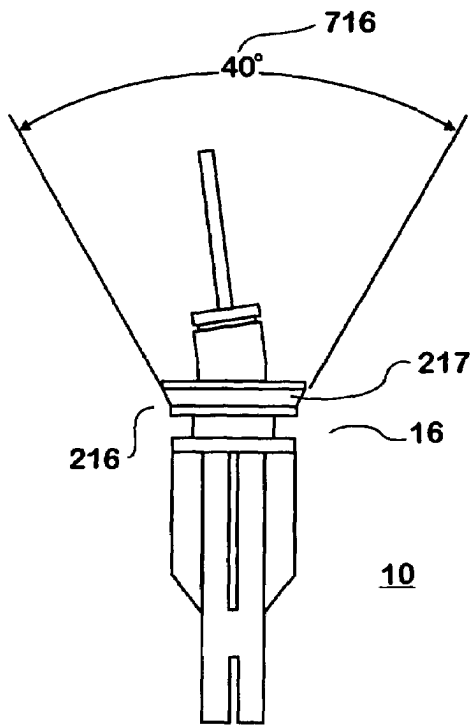
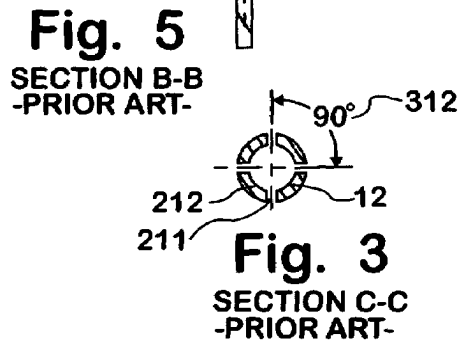
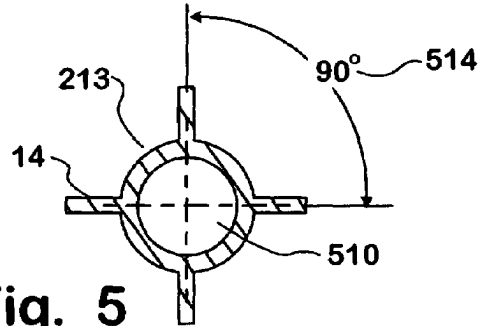
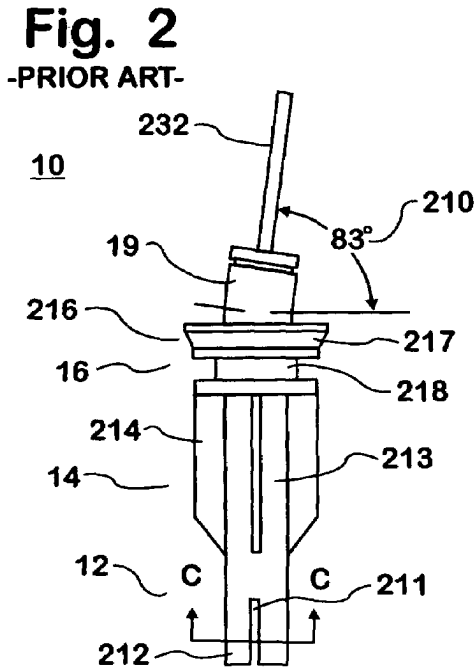
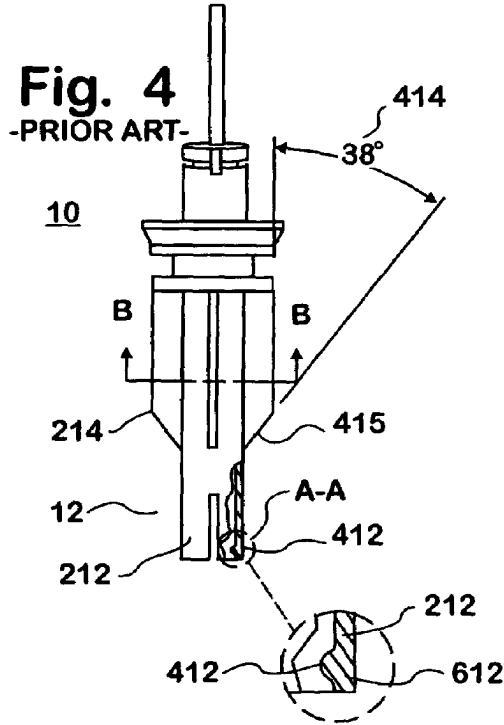

Fig. 1  
-PRIOR ART-



**Fig. 7**  
-PRIOR ART-



**Fig. 6**  
VIEW A-A  
-PRIOR ART-

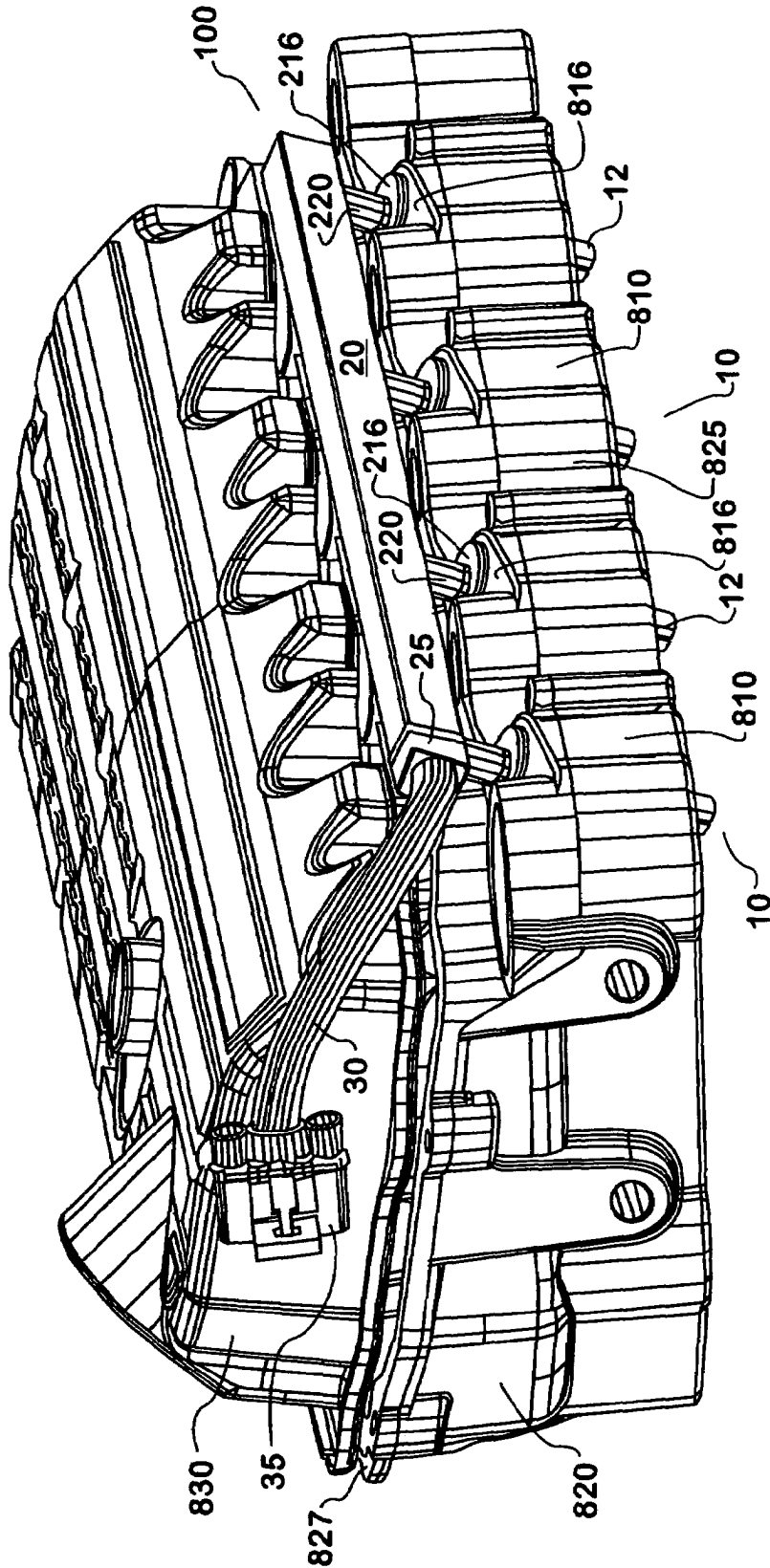

**Fig. 8**  
-PRIOR ART-

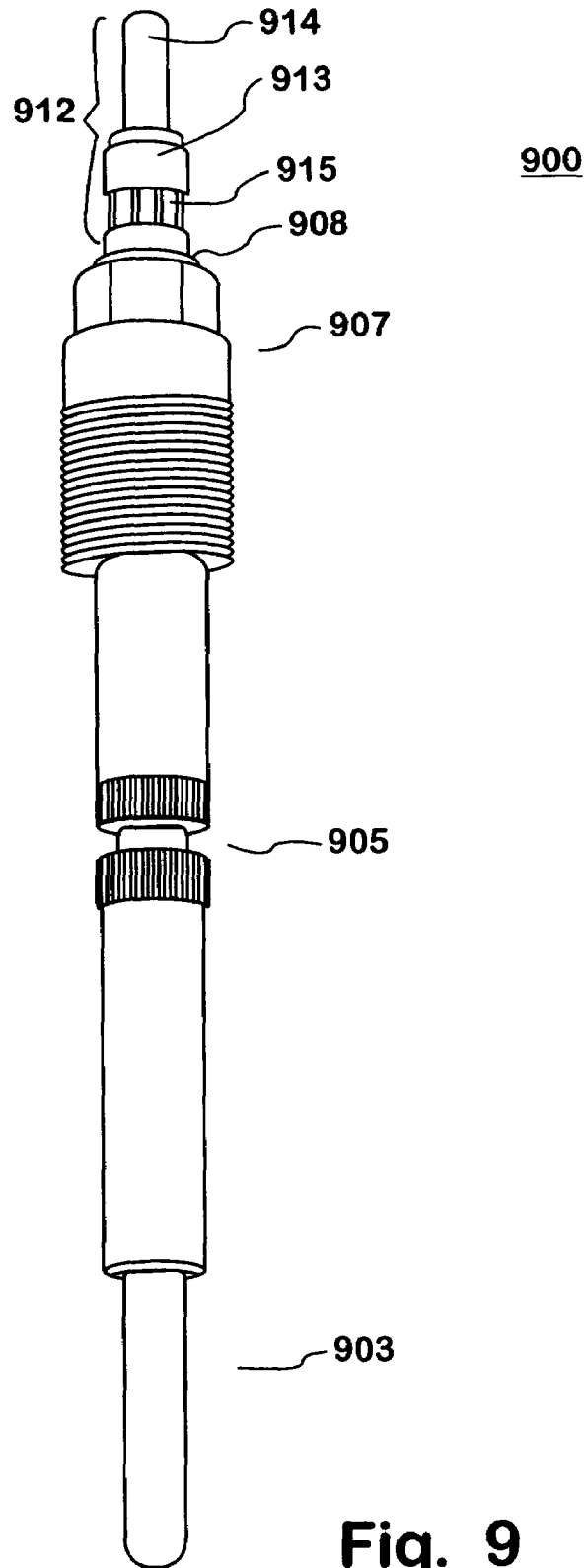

**Fig. 9**  
**-PRIOR ART-**

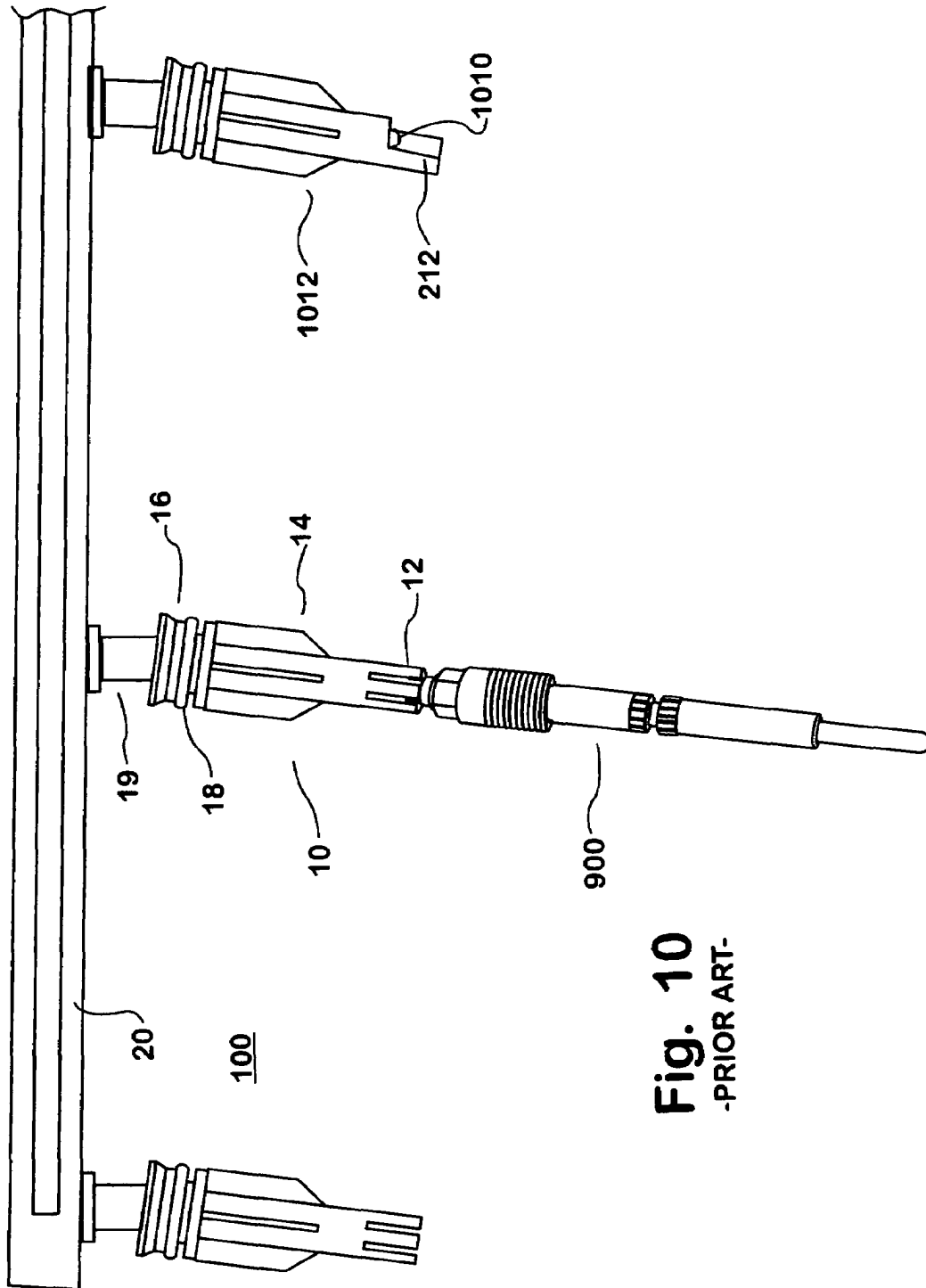

**Fig. 10**  
-PRIOR ART-

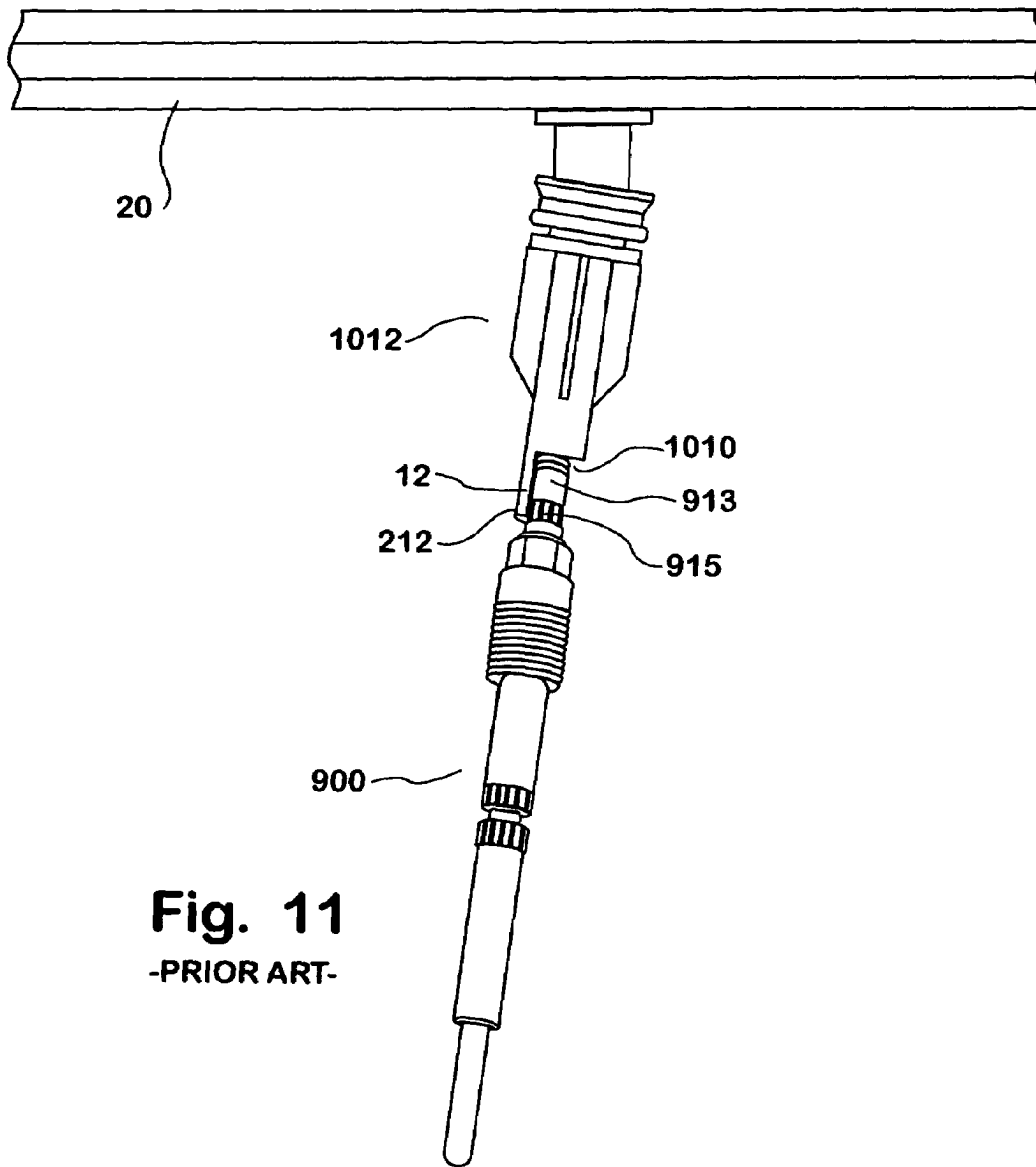

**Fig. 11**  
-PRIOR ART-

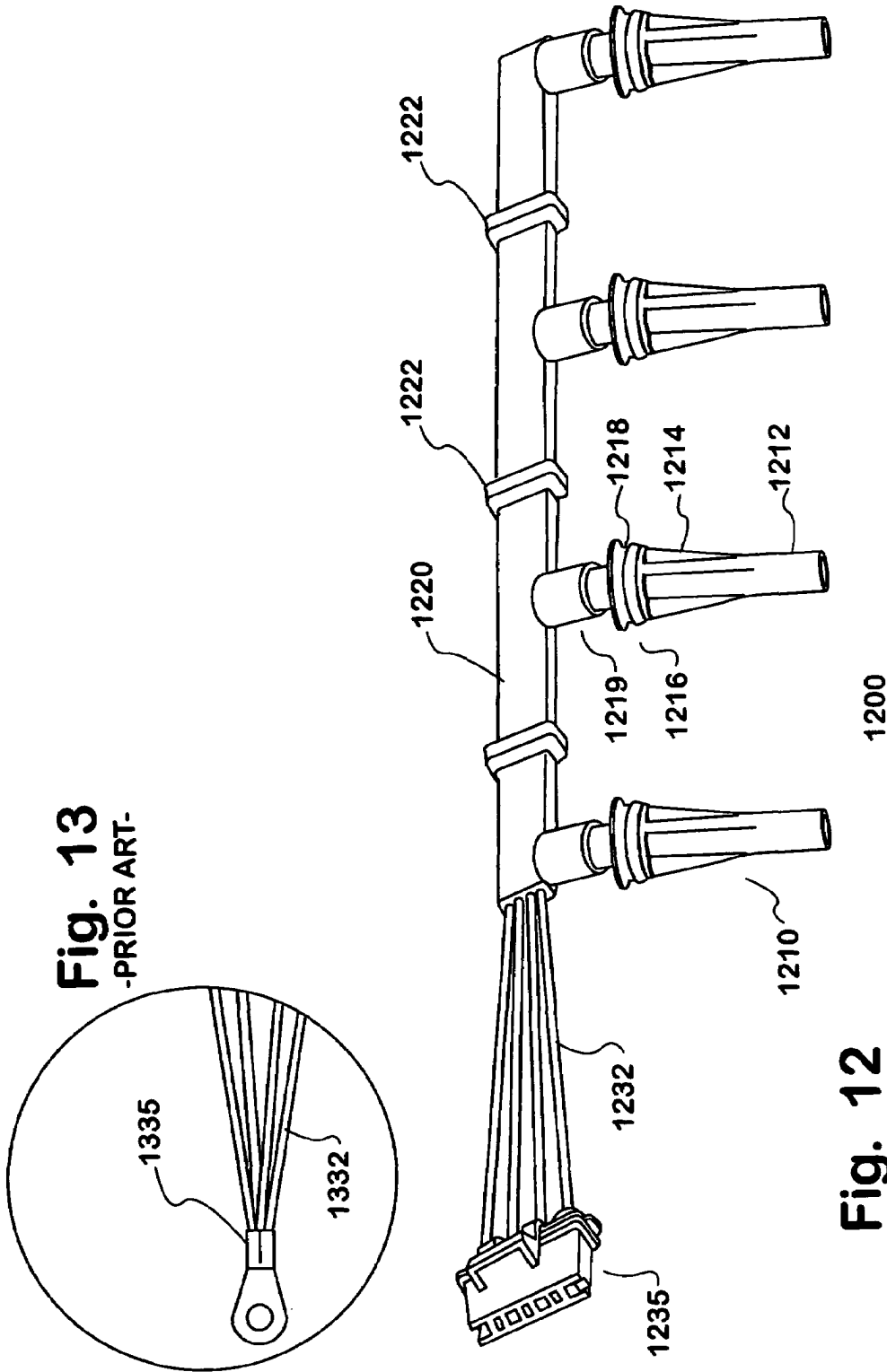

Fig. 13  
-PRIOR ART-

Fig. 12  
-PRIOR ART-



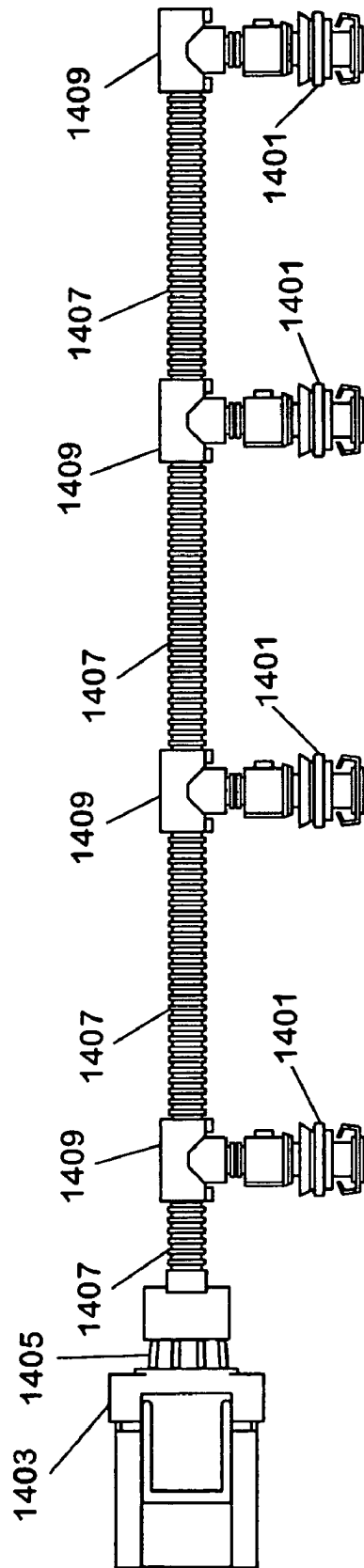

FIG. 14

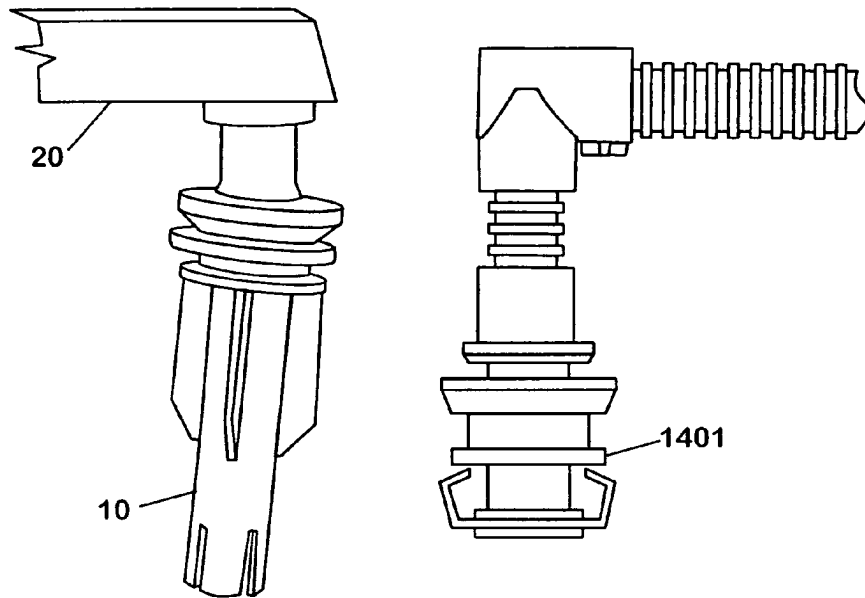

FIG. 15

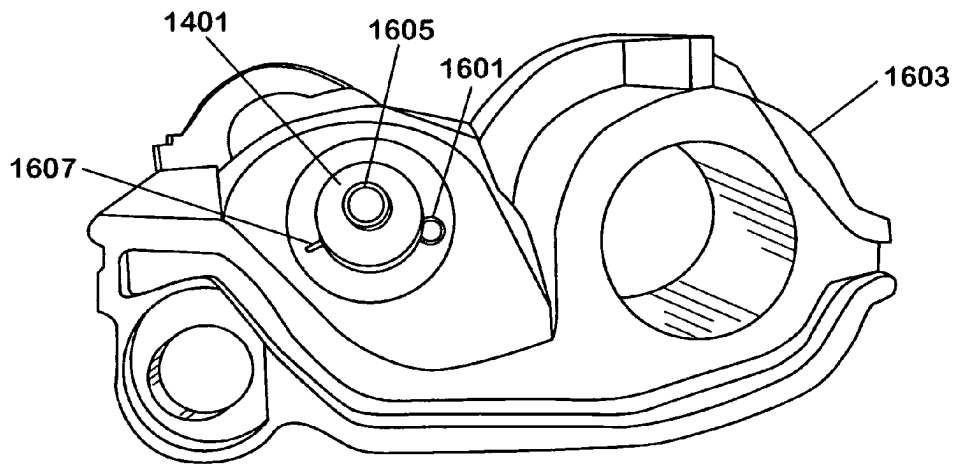
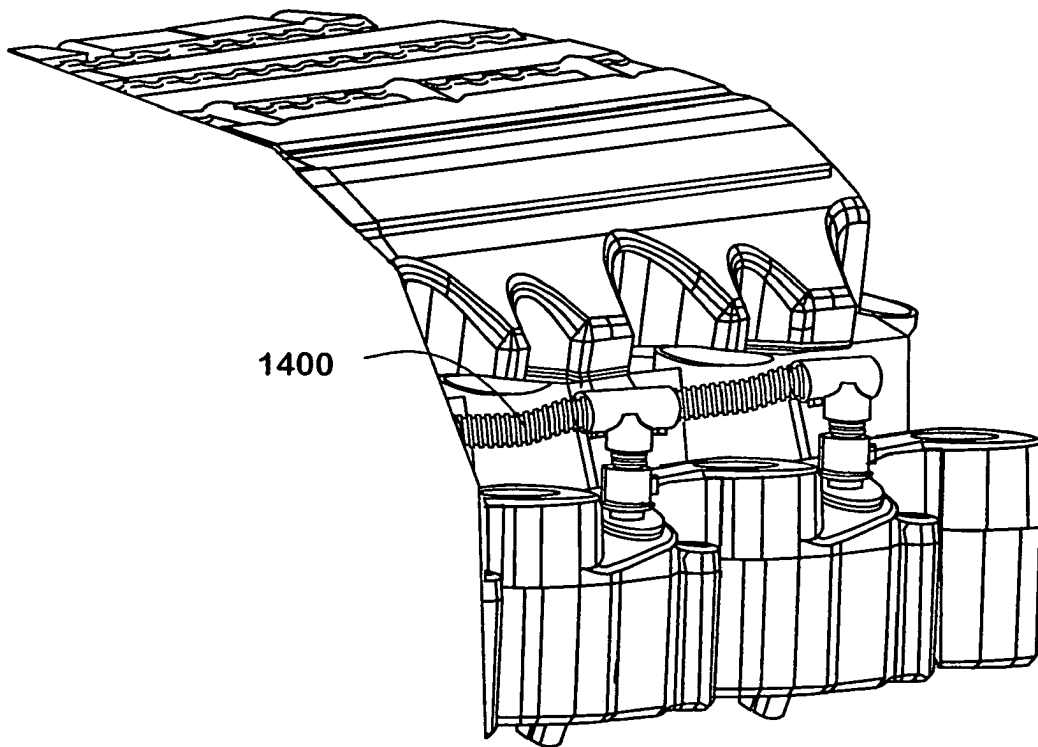
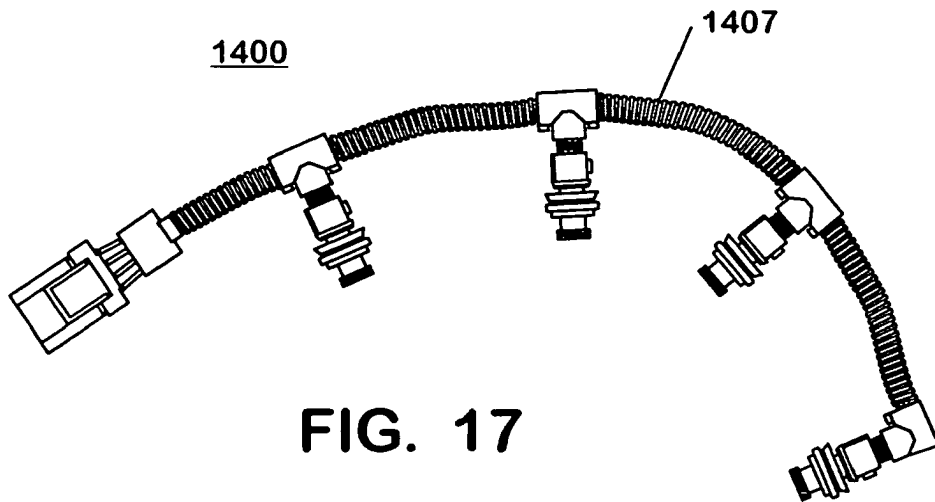

FIG. 16



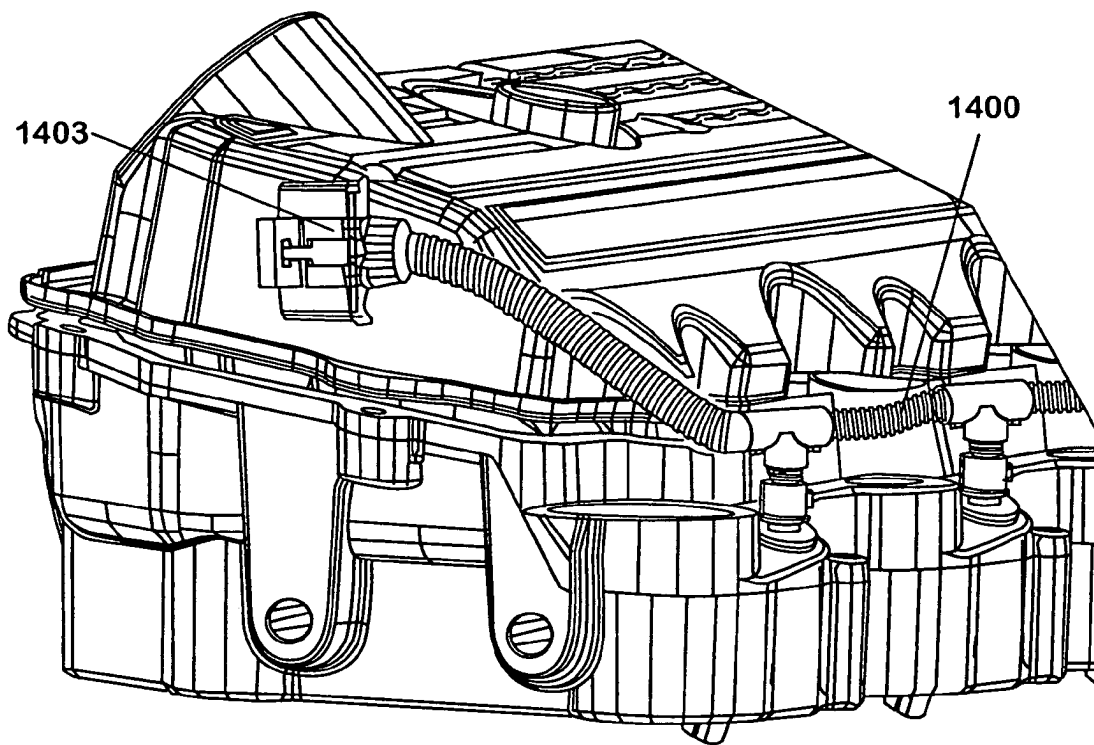

FIG. 19

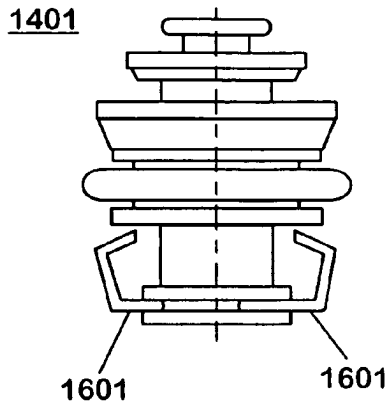

FIG. 20

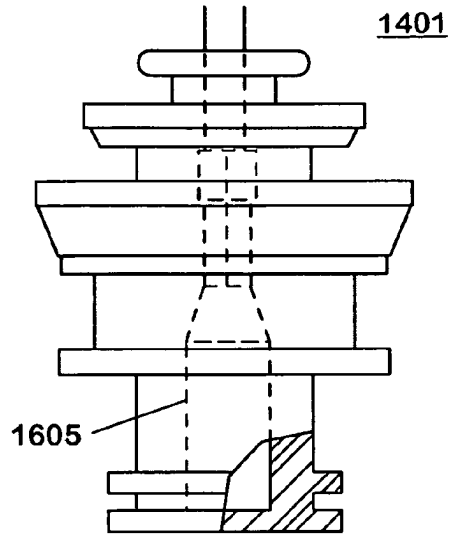

FIG. 21

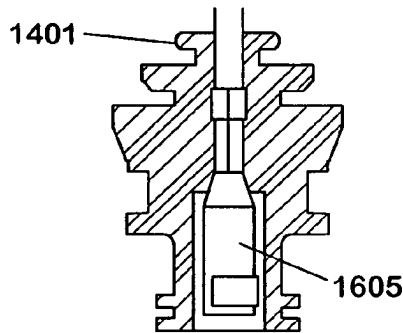

FIG. 22

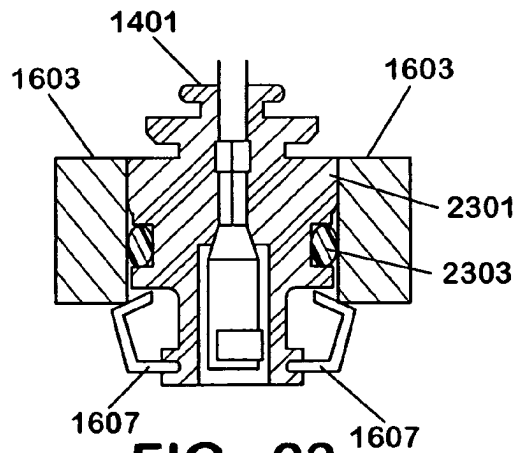

FIG. 23

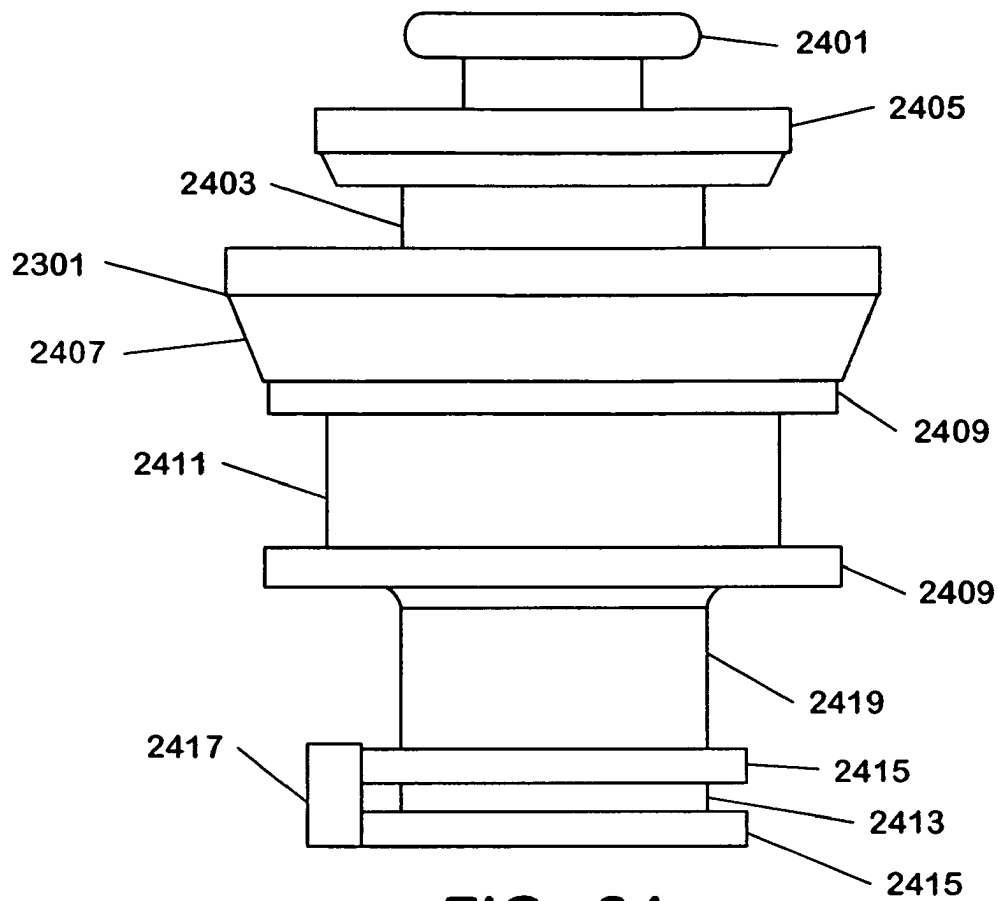

FIG. 24

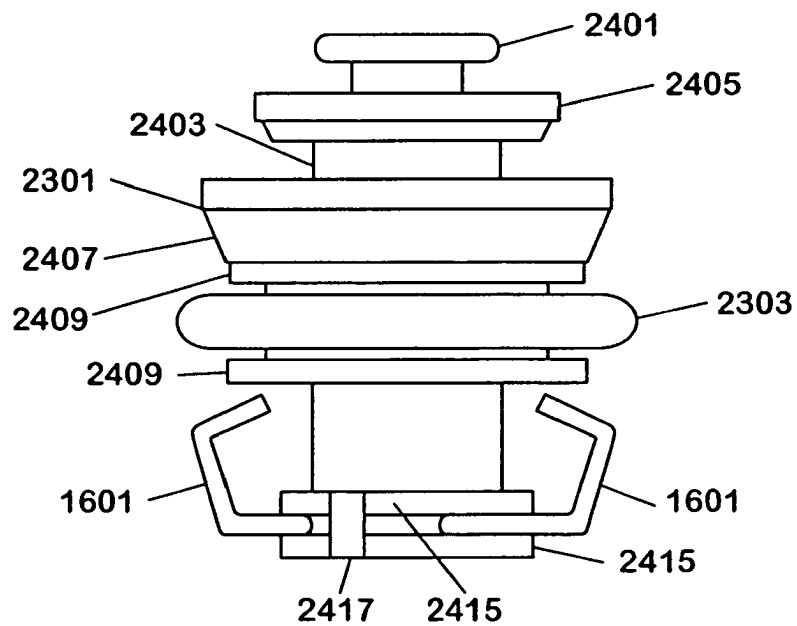

FIG. 25

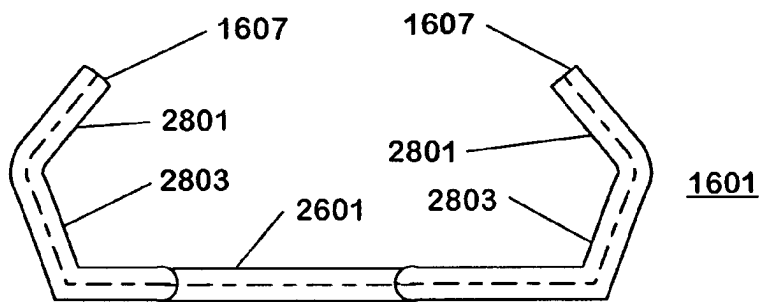
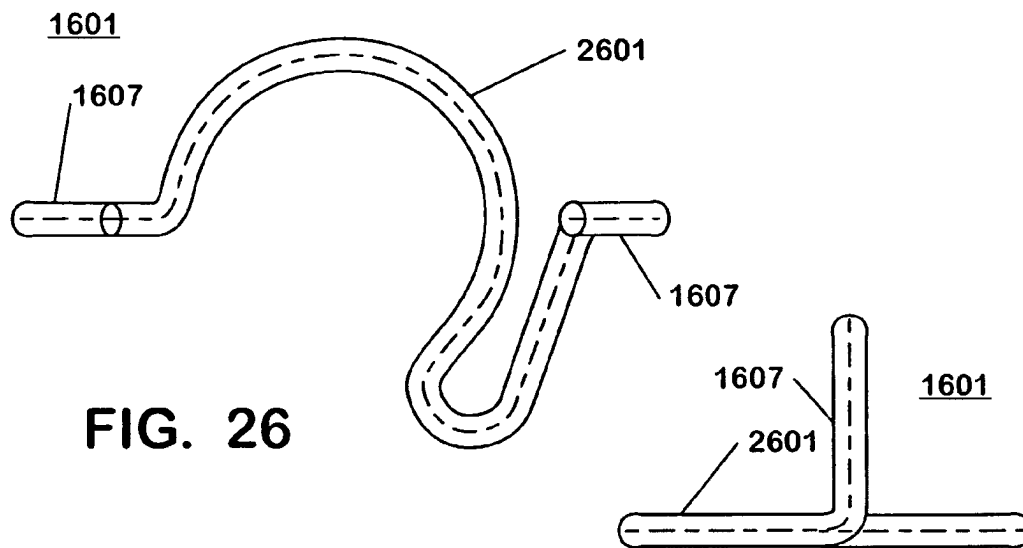

FIG. 28

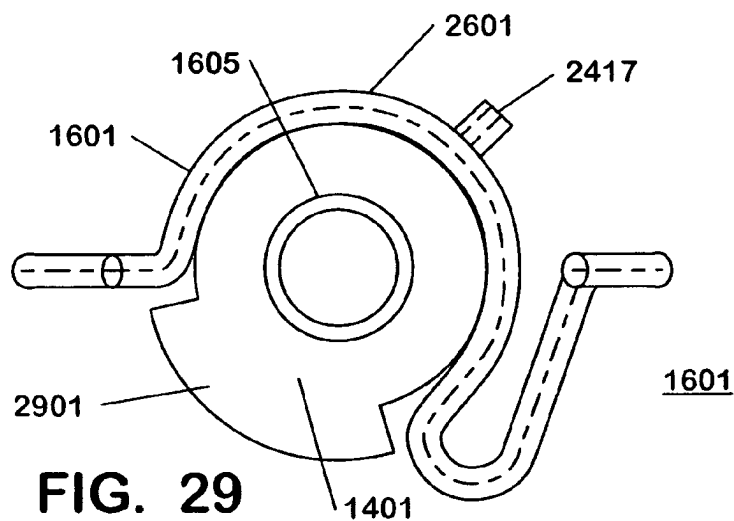

FIG. 29

## RETAINER FOR CONNECTOR

## CLAIM OF PRIORITY

This patent application claims the benefit of the priority of provisional patent application No. 60/466,867 filed Apr. 30, 2003.

## FIELD OF THE INVENTION

This invention relates to glow plugs for use with internal combustion engines, including but not limited to connectors and related apparatus for use with such glow plugs.

## BACKGROUND OF THE INVENTION

Internal combustion engines commonly employ cold start devices, such as a glow plug, to assist in ignition. Existing engine designs commonly have glow plugs located inside the engine valve cover. A glow plug is generally used to preheat the combustion chamber mixture of a diesel engine or an auto-ignition internal combustion engine to assist in cold starting. The single glow plug corresponding to a combustion chamber is generally secured to or installed in the cylinder head of the engine such that there is an equal number of combustion chambers and glow plugs. For example, a diesel engine with a V-8 configuration has a total of eight glow plugs with four glow plugs on each cylinder bank.

Each glow plug is typically electronically connected to a power source via a single glow plug connector attached to an under-cover valve cover wire harness. The under-cover valve cover wire harness is then appropriately electronically connected to an external engine harness that is in turn connected to an engine power source. The interface between under-valve cover and external harnesses provides a sealing function that prevents engine oil leakage. In the interior of the valve cover, the glow plug connectors, attached to the under-cover valve cover wire harness, are individually connected to corresponding glow plugs. This arrangement often times leads to crowding of engine components in the limited space under the valve cover. Also, the installation of each glow plug connector to each glow plug terminal results in increased manufacturing time and costs.

Further, mounting existing wire harness glow plug connectors individually to the glow plugs can be difficult, time consuming and requires some force to push and connect the wire harness connectors to the glow plug terminals. The wire harness connectors may be connected manually or with special insertion tools. Due to the limited space under the valve cover, it is difficult to individually install glow plug connectors properly to corresponding glow plug terminals. Many times, the resultant electrical connection between the glow plug connector and the glow plug terminal is at times not secure and electrically inadequate. As a result, electrical testing is typically required to verify that there is adequate electrical contact between the glow plug connector and the glow plug terminal. The required testing is a drawback that also leads to increased engine manufacturing time and cost.

Accordingly, there is a need for a glow plug connection apparatus that is easy to install, prevents engine oil leaks, and results in a consistently good electrical connection between the glow plug connector and glow plug, thereby reducing engine manufacturing time and costs.

U.S. Pat. No. 6,539,905 provides a glow plug connection apparatus for electrically connecting to a plurality of glow plugs while simultaneously sealing the engine from oil leakage. The glow plug connection apparatus simultaneously installs a plurality of glow plug connectors to corresponding glow plugs mounted in a cylinder head in an internal combustion engine. The glow plug connection apparatus comprises, a rigid buss bar rail, a plurality of glow plug connectors attached to the rigid buss bar rail, a plurality of connector wires routed in the rigid buss bar rail and electrically connected to corresponding glow plug connectors, a wire router, and a conduit retaining clip between the wire router and the rigid buss bar rail. The rigid buss bar rail and the glow plug connectors preferably form an apparatus connector angle. The glow plug connector wires can terminate in a multi-port glow plug wire connector or a single connection point.

Additionally, the glow plug connector of the glow plug connection apparatus preferably comprises a buss bar rail interface section, a sealing section having an O-ring seal able to seal the glow plug connector to a glow plug passage, a guide section having a plurality of guide fins around the periphery of the glow plug connector, and a clip section having a plurality of clip fingers around the periphery of the glow plug connector able to engage a glow plug terminal. In a preferred embodiment, at least one the clip fingers has a protruding lip. The buss bar rail interface section and the glow plug connector body preferably form a glow plug connector angle.

FIG. 1 shows a front view of an embodiment of a glow plug connection apparatus **100** according to U.S. Pat. No. 6,539,905. The glow plug connection apparatus **100** comprises a rigid routing or buss bar rail **20**, a plurality of glow plug connectors **10**, a conduit retaining clip **25**, a wire conduit **30**, glow plug connector wires **32**, and a glow plug wire connector **35**. The glow plug connection apparatus **100** is preferably adapted for mounting in a rocker carrier **820** (shown in FIG. **8**) which is mounted on a cylinder head (not shown) in an internal combustion engine. The rocker carrier is the subject of U.S. Pat. No. 6,484,683 issued Nov. 26, 2002 to Zielke. Both U.S. Pat. No. 6,539,905 and U.S. Pat. No. 6,484,683 are assigned to a common entity, International Engine Intellectual Property Company, LLC. The rocker carrier generally relates to a device for mounting and securing certain engine related components to a cylinder head, and is incorporated herein by reference.

FIG. 1 shows a four position glow plug connection apparatus **100**, with four glow plug connectors **10**, that would be connected to four corresponding glow plugs (shown in FIG. **10** and FIG. **11**) previously mounted on a cylinder head. The glow plug connection apparatus **100** depicted in FIG. **1** and FIG. **8** is preferably mounted on the rocker carrier **820** that is mounted on one cylinder head bank side of a V-8 type engine. Those of skill in the art will readily recognize that the glow plug connection apparatus **100** could also be easily modified to cooperatively mount on a rocker carrier for use on a on a six cylinder V-type engine. The glow plug connection apparatus **100** can be modified to comprise more or less glow plug connectors **10** depending on a particular engine application, e.g., three glow plug connectors **10** for one bank of a V-6 type engine. Additionally, the glow plug connection apparatus **100** shown in FIG. **1** can be mounted on a rocker carrier **820** that is mountable on either cylinder head bank or side of a V-type engine.



3

The buss bar rail **20** is preferably a rigid routing section for internally routing glow plug connector wires **32** between the glow plug connectors **10** and the glow plug wire connector **35**. The buss bar rail is preferably configured of a hollow lengthwise rigid metal or steel section with a rectangular cross-section. The bus bar rail **20** can have other configurations, for example a square, circular or oval cross-section. Further, the hollow rigid steel or metal makeup of the buss bar rail **20** allows the glow plugs wires **32** to protect the glow plug wires **32** from heat exposure in the engine compartment due to the engine or other engine components. Also, the glow plug connection apparatus **100** via the rigid buss bar rail **20** allows the glow plug connectors **10** to be simultaneously connected by pushing or pressing down on the rigid buss bar rail **20** until the glow plug connectors **10** engage the corresponding glow plugs **900** (shown in FIG. 9).

FIG. 1 shows that the buss bar rail **20** preferably comprises four glow plug connectors **10** attached substantially equidistant and parallel to each other and extending away from the buss bar rail **20** in the same direction. The glow plug connectors **10** are preferably comprised of a buss bar rail interface section **19**, a sealing section **16** with an O-ring seal **18**, a guide section **14** and a clip or snap-fit section **12**. The glow plug connectors **10** are appropriately spaced along the buss bar rail **20** to correspond to glow plugs **900** installed in an engine cylinder head. Further, due to the physical inclined positioning of the glow plugs **900** in the engine cylinder head, the glow plug connectors **10** preferably form an apparatus connector angle **8** with respect to the rigid buss bar rail **20**. In the embodiment shown in FIG. 1, the preferred apparatus connector angle **8** is about eighty-three degrees. Those of skill in the art will readily recognize that the apparatus connector angle **8** may vary to compliment the physical inclination of the glow plugs **900** in a particular engine application. The apparatus connector angle **8** also allows the buss bar rail **20** to maintain a substantially parallel relationship to the engine cylinder head or rocker carrier once installed (shown in FIG. 8).

FIG. 1 also shows a buss bar retaining clip **25** that is preferably positioned at the interface between the rigid buss bar rail **20** and the wire router or conduit **30**. The wire conduit **30** is in turn attached to the glow plug wire connector **35**. The glow plug wire connector **35** is preferably a four pin connector since there are four glow plug connectors **10** which correspond to four glow plug connector wires **32**. The glow plug wire connector **35** will be plugged into an external engine harness or to a glow plug control module (not shown) where power can then be appropriately delivered. The glow plug wire connector **35**, wire router **30** and bus buss retaining clip **25** combination is shown attached to a left side **40** of the buss bar rail **20**. Those of skill in the art will readily recognize that this combination could also be positioned on an opposite right side **50** of the buss bar rail **20** if needed by a particular engine application.

The wire router **30** is preferably a flexible dress cover for ease in moving, positioning and routing the wire router **30** in the engine compartment area. The range of movement of the wire router **30** is enhanced by the buss bar retaining clip **25** which comprises a hinge clip section **24** that moves or pivots about a middle clip point **26**. The glow plug wire connector **35** can thus be more easily routed as needed and plugged into an external engine harness or glow plug control module (not shown). Both the wire router **30** and the buss bar retaining clip **25** are preferably made up of flexible plastic based materials but other materials that allow convenient routing and movement of the glow plug wire connector **35** may be substituted.

4

FIG. 2 shows a front view of the glow plug connector **10** of the glow plug connection apparatus **100** shown in FIG. 1. The glow plug connector **10** is preferably comprised of a buss bar rail interface section **19**, a sealing section **16** for use in conjunction with an O-ring seal **18** (shown in FIG. 1), a guide section **14** and a clip or snap-fit section **12** that engages a top portion of the glow plug **913** (shown in FIG. 9). The buss bar rail interface section **19** is attached to the buss bar rail **20** as shown in FIG. 1. The buss bar interface section **19** is preferably inclined with respect to the glow plug connector body **10** by a glow plug connector angle **210**. The preferred glow plug connector angle **210** is about eighty-three degrees. However, those of skill in the art will readily recognize that the glow plug connector angle **210** may vary depending on the physical inclination of the glow plugs **900** installed in a particular engine application. The glow plug connector angle **210** allows the glow plug connector **10** and the buss bar rail **20** to be attached in such a manner that the buss bar rail **20** can maintain a substantially parallel relationship to the engine cylinder head once the glow plug connection apparatus **100** is installed. This aspect results in the apparatus connector angle **8** discussed and shown in FIG. 1. Additionally, there is shown a portion of a glow plug connector wire **232** extending from the buss bar rail interface section **19** which connects the glow plug connector **10** to the glow plug wire connector **35**.

FIG. 2 also shows in more detail the sealing section **16** that comprises an O-ring holder area **218** and a seating section **216**. The O-ring holder area **218** is configured to hold an O-ring seal **18** (shown in FIG. 1) which will seal a glow plug passage **810** (shown in FIG. 8) in the rocker carrier. The O-ring seal **18** is preferably comprised of a rubber based material, e.g., it can be a TEFLON®-coated VITON® O-ring. Other materials that accomplish the sealing function may instead be used. The seating section **216** is preferably configured to have an external tapered seating face **217**. The tapered seating face **21** engages a complementarily configured top glow plug passage section **816** (shown in FIG. 8) of the rocker carrier **820** when the glow plug connection apparatus **100** is installed. The O-ring seal **18** and the tapered seating face **217** allow the glow plug connectors **10** to be appropriately sealed in the rocker carrier **820** and to properly sit on the top glow plug passage **816** when the glow plug connection apparatus **100** is installed (shown in FIG. 8).

FIG. 2 also shows the guide section **14** which is preferably comprised of a plurality of guide fins **214** positioned in a substantially vertical manner around the periphery of a glow plug connector midsection **213**. The guide fins **214** will appropriately align or position the glow plug connector **10** in glow plug passages **810** (shown in FIG. 8) to allow the glow plug connectors **10** to more easily travel in the glow plug passages **810** and thereby more easily and properly connect with the glow plugs **900** installed in the cylinder head (not shown). The guide fins **214** also give the glow plug connector **10** added structural strength and stability. The preferred embodiment shown in FIG. 2 comprises four guide fins **214** (shown in FIG. 5) spaced equidistantly at about 90 degrees from each other around the periphery of the connector midsection **213** for positioning of the glow plug connectors **10**. Those of skill in the art will readily recognize that more or less fins could be used to accomplish the same function. Also, the degree distance **514** (shown in FIG. 5) between the guide fins **214** may be different from guide fin **214** to guide fin **214** so long as the proper positioning of the glow plug connector **10** in the glow plug passage **810** is achieved.

5

Further, FIG. 2 shows the glow plug clip section 12 at the bottom of the glow plug connector 10. The glow plug clip section 12 is preferably comprised of a plurality of clip fingers 212 positioned around the bottom periphery of the glow plug connector 10. In the embodiment shown, the glow plug clip section 12 comprises four clip fingers 212 (shown in FIG. 3) spaced equidistantly from each other around the bottom periphery of the glow plug connector 10. This physical arrangement results in finger spacings 211 between the clip fingers 212 that are equidistantly spaced at 90 degrees from each other (shown in FIG. 3). The equidistant finger spacings 211 allow for more efficient or equal distribution of forces encountered by the clip fingers 212. The clip fingers 212 preferably have a resilient and spring-like property so that they can expand and contract as required when a glow plug 900 is inserted into or removed from the glow plug connector 10. During installation of the glow plug connection apparatus 100, the clip fingers 212 expand to accept a glow plug terminal 912 (shown in FIG. 12) and then contract to secure the electrical connection to the glow plug terminal 912. Those of skill in the art will readily recognize that more or less clip fingers 212 could be used so long as the desired electrical connection of the glow plug connector 10 to the glow plug 900 is achieved and secured. Though equidistant spacing is preferred, the resultant finger spacings 211 between clip fingers 212 could be different from clip finger 212 to clip finger depending on a particular application.

FIG. 3 shows a cross-sectional view of the clip section 12 along a section line C—C of the glow plug connector 10 shown in FIG. 2. FIG. 3 clearly illustrates that in a preferred embodiment, the glow plug connector 10 clip section 12 is comprised of four clip fingers 212 equidistantly positioned around the periphery of a glow plug connector 10 and separated by four resulting finger spacings 211. The finger spacing 211 are preferably equidistantly spaced at 90 degrees apart from each other. The equidistant clip finger 212 arrangement allows for more efficient or equal distribution of forces encountered by the clip fingers 212 when a glow plug 900 is inserted or removed upon installation or removal of the glow plug connection apparatus 100.

FIG. 4 shows a side view of the glow plug connector shown in FIG. 2. A preferred configuration of the guide fins 214 is illustrated where the guide fin bottom 415 has an inclined construction. In this embodiment, the guide fin bottom 415 forms a fin angle 414 with the glow plug connector 10 of about 38 degrees. The guide fin angle 414 will ease the initial insertion of the glow plug connectors 10 into the glow plug passages 810 of the rocker carrier 820 (shown in FIG. 8). Those of skill in the art will recognize that other guide fin angles 414 would also accomplish the same function. FIG. 4 also shows a cutaway view A—A of the glow plug clip section 12 that partially highlights a preferred interior protruding lip 412 configuration of the clip fingers 212. The protruding lip 412 is an important part of the clip fingers 212 since it 412 is in part responsible for holding and securing the electrical connection between the glow plug connectors 10 to the glow plug 900.

FIG. 5 shows a cross-sectional view of the guide section 14 along the section line B—B of the glow plug connector 10 shown in FIG. 4. FIG. 5 shows that in the preferred embodiment, the glow plug 10 is comprised of four guide fins 214 spaced equidistantly at 90 degrees from each other around the periphery of the connector midsection 213. As noted previously, the guide fins 214 properly align or position the glow plug connector 10 in the glow plug passages 810 of the rocker carrier 820. More or less guide

6

fins 214 could be used and the degree distance 514 between the guide fins 214 may be different from guide fin 214 to guide fin 214 so long as the proper alignment or positioning of the glow plug connector 10 in the glow plug passage 810 is achieved. FIG. 5 also shows the glow plug connector interior 510 which will preferably house a female type connector 1010 (shown in FIG. 10 and FIG. 11). The female type connector 1010 is internally electrically connected (not shown) to the glow plug connector wire 32 (shown in FIG. 1) and accepts the insertion of the glow plug terminal tip 914 (shown in FIG. 9 and FIG. 11).

FIG. 6 shows an enlarged detail of view A—A of the clip section 12 of the glow plug connector 10 showing a preferred interior configuration of the clip finger 212. The interiorly protruding lip 412 is an important aspect of the clip fingers 212. In conjunction with the resilient and spring-like nature of the clip fingers 212, it is the protruding lip 412 that is responsible for ultimately holding and securing the electrical connection between the glow plug connectors 10 to the glow plug 900. The protruding lip 412 preferably extends along the interior periphery of the clip finger 212 near the finger bottom 612 and each clip finger 212 preferably has a protruding lip 412. This allows for a better and more secure connection between the glow plug connectors 10 to the glow plug 900. Those of skill in the art will readily recognize that the protruding lip 412 could also extend only partially along the interior of the clip finger 212 or could be present in less than all the clip fingers 212. The preferred configuration of the clip fingers 212 results in a “snap-on” or “click-on” feature that allows an operator or installer to know when the glow plug connectors 10 are properly installed on the glow plugs 900.

FIG. 7 shows a rear view of the glow plug connector shown in FIG. 2. More particularly, FIG. 7 shows that the seating section 216 has a tapered seating face angle 716, which is preferably about 40 degrees. The tapered seating face 217 will interact with a complementarily configured top glow plug passage section 816 of the glow plug passage 810 (shown in FIG. 8). The tapered seating face 217 allows the glow plug connectors 10 to properly sit on or engage the top glow plug passage section 816 of the glow plug passage once the glow plug connection apparatus 100 is installed (shown in FIG. 8). The tapered seating face angle 716 may take on other values complementary to the top glow plug passage section 816.

FIG. 8 shows an embodiment of the rigid glow plug connection apparatus 100 mounted on a rocker carrier 820 with a valve cover 830, where the four glow plug connectors 10 are preferably mounted in the respective glow plug passages 810 of the rocker carrier 820. There is shown a rocker carrier 820 adapted for use with a cylinder head (not shown) in an internal combustion engine, e.g., on either engine bank or side of a V-8 type diesel engine. There is also shown a valve cover 830 that secures to the top periphery 827 of the rocker carrier 820 to thereby enclose the cylinder head. One of the various features of the rocker carrier 820 is that rocker arm assemblies with associated rocker arms (not shown) and other related components can be mounted to the rocker carrier 820.

Among other configurations, the rocker carrier 820 comprises a plurality of glow plug passages 810 in or adjacent to a front rocker carrier wall 825. The glow plug passages 810 preferably have an inclined or angled configuration in the front wall 825 of the rocker carrier 820. In this manner, the glow plug passages 810 are complementarily to the angled or inclined glow plug connectors 10 of the glow plug connection apparatus 100. There is also shown the inclined

nature of the top glow plug passage section **816** of the glow plug passage **810**. The top glow plug passage section **816** is preferably configured or angled to compliment the angled or inclined tapered seating face **217** (shown in FIG. 2) of the glow plug connector **10** sealing section **16**. In this manner, the connection to the glow plugs **900** (shown in FIG. 9 through FIG. 11) can be appropriately sealed via the O-ring seal **18** (shown in FIG. 1) on the sealing section **16**.

In order to install the glow plug connection apparatus **100** (also shown in FIG. 2), an installer preferably positions the buss bar rail **20** such that all the glow plug connectors **10** are inserted into the appropriate glow plug passages **810** of the rocker carrier **820**. Next, the installer pushes or presses downward on the rigid buss bar rail **20** which thereby applies simultaneous force on the glow plug connectors **10**. The glow plug guide sections **14**, via the guide fins **414**, align the glow plug connectors **10**, as force is applied, for proper electrical connection to the glow plug terminal **912**. This allows the glow plug connectors **10** to be simultaneously connected when the glow plug connectors **10** engage corresponding glow plug terminals **914** on the glow plugs **900** (shown in FIG. 9).

As the glow plug connectors **10** are pushed into place, the each glow plug terminal **912** enters the connector clip section **12**. As the glow plug connector **10** continues moving downward, the glow plug clip fingers **212** encounter the glow plug terminal head **913**. At this point, the configuration of the glow plug terminal head **913** forces the clip fingers **212** to expand as they continue to travel downward. When the clip section **12** reaches the glow plug terminal neck **915** the clip fingers **212** will rapidly contract and compressively seat around the periphery of the glow plug terminal neck **915**. This rapid contraction results in a "snap" or "click" that typically should be audible to the installer. The installer also should be able to "feel" when the clip fingers have snapped onto the glow plug **900**. Thus, the installer will know that there is a good electrical connection when he hears or "feels" the glow plug connectors **10** "snap-on" or "click-on" to the glow plug terminals **912**.

At this point, the glow plug terminal tip **914** is inserted and electrically connected to the female type connector **1010** in the glow plug connection interior (shown in FIG. 10 and FIG. 11) which is in turn connected (not shown) to the glow plug connector wire **32** (shown in FIG. 1). Also, the glow plug connectors **10** are now appropriately sealed against the glow plug passages **810** via the O-ring seal **18** and tapered seating face **217** of the sealing section **16** acting on the top glow plug passage section **816**. If the glow plug connectors **10** are not properly installed, the O-ring seal should be visible. This is a signal to the installer that the glow plug connection apparatus needs to be reinstalled. Further, the rigid buss bar rail **20** should now be substantially parallel to the engine cylinder head (not shown) upon which the rocker carrier **820** is or will be installed. The rigid buss bar rail **20** is preferably parallel to the engine cylinder head to, among other things, minimize the amount of space used in the engine compartment. The glow plug wire connector **35** can now be plugged into an external engine harness, glow plug control module or other appropriate engine component for delivery of power to the glow plugs.

FIG. 9 shows a typical glow plug **900** that could be used with the glow plug connectors shown in FIG. 1 through 8. The glow plug **900** generally comprises a glow plug terminal **912**, a cylindrical metal glow plug tube or body **905** and a heating element **903**. The cylindrical tube **905** comprises the housing of the glow plug **900** that attaches to the cylinder head or engine block (not shown). The glow plug **900** is

preferably threaded to the cylinder head or engine block via glow plug threads **907** on the exterior of the glow plug **900**. The is also a glow plug terminal **912** at the top of the glow plug **900** that is insulated **908** from the glow plug body **905** and electrically connected to the heating element **903**. The glow plug terminal **912** is comprised of a terminal tip **914**, a terminal head **915** and a terminal neck **915**. The heating element **903** is generally comprised of a ceramic heating element tip **903** that will heat up when power or electric current is applied to the glow plug terminal **912** to provide heat to the diesel mixture in the combustion chamber (not shown).

As discussed previously with respect to FIG. 8, the glow plug terminal tip **914** is inserted and electrically connected to the female type connector **1010** (shown in FIG. 10 and FIG. 11) which is in turn connected (not shown) to the glow plug connector wire **32** (shown in FIG. 1). Also, the configuration of the glow plug terminal head **913** forces the resilient connector clip fingers **212** to expand as they travel around the terminal head **913**. When the resilient connector clip section **12** reaches the glow plug terminal neck **915**, the resilient connector clip fingers **212** rapidly contract and compressively seat around the periphery of the glow plug terminal neck **915**. The installer will hear or "feel" when the connector clip fingers **212** snap or click onto the glow plug **900**. The configuration of the glow plug terminal **914** and the make up of the glow plug connector **10** allows the installer to know when there is a good electrical connection when he/she hears or "feels" the glow plug connectors **10** "snap-on" or "click-on" to the glow plug terminal neck **915**.

FIG. 10 shows a front view of an embodiment of the glow plug connection apparatus **100** with an installed glow plug **900**. FIG. 10 shows three glow plug connectors **10** attached to the rigid buss bar rail **20** in a substantially equidistant and parallel manner and extending away from the buss bar rail **20**. FIG. 10 also depicts a cutaway glow plug connector **1012** with a female type connector **1010** which is housed in the glow plug connector interior **510** (shown in FIG. 5). The female type connector **1010** is internally electrically connected (not shown) to the glow plug connector wire **32** (shown in FIG. 1) and accepts the insertion of the glow plug terminal **912** (shown in FIG. 11). There is also shown the clip fingers **212** of the snap fit section **12** that will additionally secure the glow plug connector **10** to the glow plug **900** at the glow plug terminal **912**.

FIG. 11 shows the cutaway glow plug connector **1012** of FIG. 10 with an installed glow **900**. FIG. 11 shows that the terminal tip **914** of the glow plug terminal **912** is inserted in the female type connector **1010** of the glow plug connector **1012**. FIG. 11 also shows that the clip fingers **212** extend past the glow plug terminal head **913** and down to the glow plug terminal neck **912** to secure and connect the glow plug connectors **10** and **1012** to the glow plug **900**.

FIG. 12 shows a perspective front view of an alternate embodiment of the glow plug connection apparatus **1200** adapted for mounting in a rocker carrier **820**, similar to that shown in FIG. 8. The embodiment of the glow plug connection apparatus **1200** shown in FIG. 12 preferably comprises a rigid buss bar rail **1220**, a plurality of glow plug connectors **1210**, glow plug connector wires **1232**, and a glow plug wire connector **1235**. The rigid bus bar rail **1220**, of this embodiment, additionally comprises strengthening and support sections **1222**. The rigid buss bar **1220** has four glow plug connectors **1210** attached in a substantially equidistant and parallel manner and extending away from the buss bar rail **1220** in the same direction. The glow plug connectors **10** are preferably comprised of a buss bar rail

interface section **1219**, a sealing section **1216** with an O-ring seal **1218**, a guide section **1214** and a clip or snap-fit section **1212** that engages the glow plug **900** (similar to that shown in FIG. **10**). The glow plug connection apparatus **1210** is connected to the rocker carrier **820** (shown in FIG. **8**) and the glow plugs (shown in FIG. **9**) in a fashion as previously described in FIG. **8**.

FIG. **13** shows a partial view of an alternate embodiment of the termination of the glow plug connector wires **1332**. In this embodiment, the glow plug connector wires **1332** preferably terminate at a single connection point **1335** instead of a multi-port glow plug wire connector **35** and **1235** as depicted in FIG. **1** and FIG. **12**. In this embodiment, the glow plug connector wires **1332** have a single termination point thus power or electrical current is either provided to all or none of the glow plugs **900** (not shown) simultaneously. This is a configuration that could be useful in some engine applications.

#### BRIEF DESCRIPTION OF THE DRAWINGS

FIG. **1** through FIG. **13** illustrate a glow plug connection apparatus in various views from U.S. Pat. No. 6,539,905.

FIG. **14** is a harness assembly in accordance with the invention.

FIG. **15** is a close-up of the glow plug connector in accordance with the invention.

FIG. **16** is a properly inserted glow plug connector within a part of a rocker carrier **1603** in accordance with the invention.

FIG. **17** is a harness assembly that utilizes flexible wire conduit in accordance with the invention.

FIG. **18** and FIG. **19** illustrate the harness assembly with each glow plug connector inserted into the rocker carrier in accordance with the invention.

FIG. **20** is a side view of the glow plug connector with a retainer installed in accordance with the invention.

FIG. **21** is an inner glow plug terminal disposed within the glow plug connector in accordance with the invention.

FIG. **22** is a cross-sectional view of the connector showing the glow plug terminal in relation to the glow plug connector in accordance with the invention.

FIG. **23** is illustrates a cross-section of the glow plug connector disposed within a rocker carrier in accordance with the invention.

FIG. **24** illustrates a side view of the glow plug connector without a seal and retainer in accordance with the invention.

FIG. **25** illustrates a side view of the glow plug connector with a seal and retainer in accordance with the invention.

FIG. **26** is a top view of the retainer in accordance with the invention.

FIG. **27** illustrates retention arms disposed with respect to an expandable spring in accordance with the invention.

FIG. **28** is a side view of the retainer in accordance with the invention.

FIG. **29** is a cross-section of the connector as taken through the retainer groove in accordance with the invention.

#### DETAILED DESCRIPTION

The following describes an apparatus for and method of connecting wires to a glow plug. A harness assembly includes a plurality of glow plug connectors, each of which connects to a glow plug for an internal combustion engine. The harness assembly and glow plug connectors described

herein may be modified for use with spark plugs and engine sensors, including multi-wire sensors.

FIG. **14** shows a harness assembly **1400** for a plurality of glow plug connectors **1401**. The harness assembly **1400** includes a glow plug wire connector **1403** that connects a power source to glow plug wires **1405** for each of the glow plug connectors **1401**. The glow plug wires **1405** extend through a wire conduit **1407**, which may be flexible or rigid wire conduit, and a T-connector **1409** for each glow plug connector **1401**. A close-up of the glow plug connector **1401** is shown in FIG. **15**.

FIG. **16** illustrates a properly inserted glow plug connector **1401** within a part of a rocker carrier **1603**, as viewed from inside the rocker carrier **1603** where the glow plugs are disposed. Inside each glow plug connector **1401** is a glow plug terminal **1605** that provides electrical connection to the glow plug, as shown in FIG. **16**. A retention arm **1607** that is part of a retainer **1601** is also shown.

FIG. **17** shows a harness assembly **1400** that utilizes flexible wire conduit **1407**. FIG. **18** and FIG. **19** illustrate the harness assembly **1400** with each glow plug connector **1401** inserted into the rocker carrier **1603** of an internal combustion engine. The harness assembly **1400** and/or glow plug connectors **1401** described herein may be utilized, for example, with V-type, inline, or L-type engines.

FIG. **20** is a side view of the glow plug connector **1401** with the retainer **1601** installed. FIG. **21** illustrates the inner glow plug terminal **1605** disposed within the glow plug connector **1401**. FIG. **22** is a cross-sectional view of the glow plug connector **1401** showing the glow plug terminal **1605** in relation to the connector **1401**. The part of the glow plug connector **1401** that surrounds the glow plug terminal **1605** may be comprised of velox material.

FIG. **23** illustrates a cross-section of the glow plug connector **1401** disposed within an opening in a rocker carrier **1603**, showing compression of an O-ring seal **2303** and a stopper **2301**. Once the outer diameter of the O-ring seal **2303** is no longer visible above the rocker carrier **1603**, the glow plug connector **1401** is properly mounted. Once the glow plug connector **1401** is installed, retention arms **1607** for the retainer **1601** expand below the surface of the rocker carrier **1603**.

FIG. **24** illustrates a side view of the glow plug connector **1401** without the seal **2303** and the retainer **1601**, and FIG. **25** illustrates a side view of the glow plug connector **1401** with the seal **2303** and the retainer **1601**. An upper flange **2401** is encased within a lower portion of the T-connector **1409**, as shown in FIG. **14**. An installation tool groove **2403** is located between an installation flange **2405** and the stopper **2301** of the connector **1401**. An installation tool is inserted into the installation tool groove **2403** in order to assist with the installation and removal of the glow plug connector **1401**.

The stopper **2301** is advantageously configured to have an external tapered seating face **2407**. The tapered seating face **2407** engages a complementarily configured top glow plug passage section **816** (shown in FIG. **8**) of the rocker carrier **1603** when the glow plug connector **1401** is installed. The O-ring seal **2303** and the tapered seating face **2407** allow the glow plug connectors **1401** to be appropriately sealed in the rocker carrier **1603** and to be properly disposed in the top glow plug passage **816** when the glow plug connectors **1401** are installed.

A pair of seal flanges **2409** and a seal groove **2411** are configured to hold an O-ring type seal **2303** as shown in FIG. **23** and FIG. **25** to seal a glow plug passage **810** (as shown in FIG. **8**) in the rocker carrier **1603**. The O-ring seal **2303**

11

is advantageously comprised of a rubber-based material, e.g., a Teflon coated Viton O-ring. Other materials may instead be utilized to accomplish the sealing function.

A retainer groove 2413 is disposed between a pair of retainer flanges 2415 such that the retainer 1601 may be disposed in the groove between the retainer flanges 2415. An optional overmold 2417 is provided to secure the retainer 1601 to the connector 1401, thereby preventing the retainer 1601 from becoming dislodged from the connector 1401. A spacer 2419 is disposed between the seal flanges 2409 and the retainer flanges 2415 to provide a suitable length for the glow plug connector 1401 to mate with the glow plug.

FIG. 26 illustrates a top view of the retainer 1601. The retainer 1601 is used to positively retain the glow plug connector 1401 in the rocker carrier 1603. The retention arms 1607 are angled on both sides, allowing the retainer 1601 to compress as the glow plug connector 1401 is inserted into the rocker carrier 1603 and to snap back to its full dimensions once inside the engine. The angle on the opposite side allows the connector 1401 to also be removed from the rocker carrier 1603 without damage to either the connector 1401 or the engine. The retainer 1601 is advantageously comprised of a metal or metal alloy that is compressible, expandable, and at least slightly flexible. A retention arm 1607 is disposed at each end of an expandable spring 2601. The expandable spring 2601 expands as it encompasses the retainer groove 2413, then contracts slightly once in place (as shown in FIG. 29). The expandable spring 2601 advantageously has curved section having a partially circular segment at one end and a u-shaped section at the other end. The retention arms 1607 are disposed at each end of the expandable spring 2601. Compression of the retention arms 1607 toward each other compresses the expandable spring 2601, and driving the retention arms 1607 apart expands the expandable spring 2601. The retention arms 1607 are advantageously disposed perpendicular to the expandable spring 2601, as shown in FIG. 27.

FIG. 28 illustrates a side view of the retainer 1601. The retention arms 1607 are shown each comprising an outer member 2801 and an inner member 2803 that are disposed at an angle with respect to each other. The retention arms 1607 may advantageously be disposed in the same plane, and the retention arms 1607 may advantageously be disposed in a plane substantially perpendicular to the plane in which the expandable spring 2601 is disposed. When the glow plug connector 1401 is inserted into the rocker carrier 1603, the inner members 2803 compress such that the retainer 1601 fits within the glow plug passage 810 of the rocker carrier 1603 as the glow plug connector 1401 is inserted. Once the elbow, where the outer member 2801 and inner member 2803 meet, clears the end of the glow plug passage 810, the retention arms 1607 expand and hold the glow plug connector 1401 in the rocker carrier 1603. When the glow plug connector 1401 is removed from the rocker carrier 1603, the outer members 2801 compress such that the retainer 1601 fits within the glow plug passage 810 of the rocker carrier 1603 as the glow plug connector 1401 is removed.

FIG. 29 shows a cross-section of the connector as taken through the retainer groove 2413, when the retainer 1601 is disposed on the connector 1401. The retainer groove 2413 advantageously runs only partially around the outer diameter of the glow plug connector 1401 between the retainer flanges 2415. A retainer locator 2901 between the retainer flanges 2415 is utilized to orient the retainer 1601 to the glow plug connector 1401, with a certain amount of play between the retainer 1601 and the retainer locator 2901.

12

The present invention provides the advantage of positively connecting glow plug connectors within a rocker carrier by use of a retainer. The retainer is flexible, which facilitates installation and removal, in addition to securing the glow plug connector within the rocker carrier. Installation and removal are facilitated by providing a groove in which an installation tool may be inserted. The apparatus may be utilized in other applications than glow plug connection.

The present invention may be embodied in other specific forms without departing from its spirit or essential characteristics. The described embodiments are to be considered in all respects only as illustrative and not restrictive. The scope of the invention is, therefore, indicated by the appended claims rather than by the foregoing description. All changes that come within the meaning and range of equivalency of the claims are to be embraced within their scope.

What is claimed is:

1. A glow plug connector comprising:

a glow plug terminal;

a first retainer flange and a second retainer flange;

a retainer disposed between the first retainer flange and the second retainer flange, wherein the retainer is capable of compressing to fit within a passage of a rocker carrier and capable of subsequently expanding to prevent the glow plug connector from being dislodged from the rocker carrier.

2. The glow plug connector of claim 1, wherein the retainer is comprised of at least one retention arm including an outer member disposed at an angle from an inner member, wherein the at least one retention arm is compressible.

3. The glow plug connector of claim 1, wherein the retainer is comprised of an expandable spring having a first end and a second end, and wherein a first retention arm is disposed at the first end and a second retention arm is disposed at the second end.

4. The glow plug connector of claim 1, wherein the retainer is comprised of an expandable spring having a curved section, a first end, and a second end, wherein the curved section comprises a partial ring section and a u-shaped section, and wherein a first retention arm is disposed at the first end and a second retention arm is disposed at a second end.

5. The glow plug connector of claim 1, further comprising an installation tool groove disposed adjacent to an installation flange.

6. The glow plug connector of claim 1, further comprising an overmold disposed adjacent to the first retainer flange and the second retainer flange such that the retainer is secured in a groove between the first retainer flange, the second retainer flange, and the overmold.

7. The glow plug connector of claim 1, further comprising a stopper capable of compressing within an opening of a rocker carrier.

8. The glow plug connector of claim 1, further comprising:

a first seal flange and a second seal flange separated by a seal groove;

a seal disposed in the seal groove.

9. An apparatus comprising:

an electrical terminal;

a first retainer flange and a second retainer flange;

a retainer disposed between the first retainer flange and the second retainer flange, wherein the retainer is capable of compressing to fit within a passage of an internal combustion engine and capable of subse-

13

quently expanding to prevent the apparatus from being dislodged from the internal combustion engine; wherein the retainer comprises a first compressible retention arm disposed at a first end of a curved section that comprises a partially circular segment at the first end and a u-shaped section at a second end the curved section, and wherein a second compressible retention arm is disposed at the second end the curved section such that compression of the first compressible retention arm and the second compressible retention arm compresses the curved section.

10. The apparatus of claim 9, wherein the retainer is comprised of at least one retention arm including an outer member disposed at an angle from an inner member, wherein the at least one retention arm is compressible.

11. The apparatus of claim 9, further comprising an installation tool groove disposed adjacent to an installation flange.

12. The apparatus of claim 9, further comprising an overmold disposed adjacent to the first retainer flange and the second retainer flange such that the retainer is secured in a groove between the first retainer flange, the second retainer flange, and the overmold.

13. The apparatus of claim 9, further comprising a stopper capable of compressing within an opening of a rocker carrier.

14. The glow plug connector of claim 9, further comprising:

a first seal flange and a second seal flange separated by a seal groove;

a seal disposed in the seal groove.

15. A retainer comprising:

an expandable spring comprising a partially circular segment adjacent to a u-shaped section, wherein the partially circular segment is capable of surrounding a part of a connector;

a first compressible retention arm disposed at a first end of the expandable spring;

14

a second compressible retention arm disposed at a second end of the expandable spring;

wherein bringing the first compressible retention arm and the second compressible retention arm together compresses the expandable spring;

wherein driving the first compressible retention arm and the second compressible retention arm apart causes the expandable spring to expand.

16. The retainer of claim 15, wherein the retainer is comprised of at least one retention arm including an outer member disposed at an angle from an inner member, wherein the at least one retention arm is compressible.

17. A retainer comprising:

an expandable spring having a curved section capable of being disposed within a groove of a connector and having a first end and a second end;

a first flexible retention arm, disposed at the first end and oriented substantially in a plane perpendicular to a plane in which the expandable spring is disposed, having an inner member disposed at a first angle outwardly from the expandable spring and an outer member disposed at a second angle inwardly toward the expandable spring, such that the inner member and the outer member form an elbow.

18. The retainer of claim 17, further comprising a second flexible retention arm, disposed at the second end and oriented substantially in the plane perpendicular to the plane in which the expandable spring is disposed, having an inner member disposed at a third angle outwardly from the expandable spring and an outer member disposed at a fourth angle inwardly toward the expandable spring, such that the inner member and the outer member form an elbow.

19. The retainer of claim 17, wherein the expandable spring comprises two or more at least partial loops.

\* \* \* \* \*